



- ✧ Build-in dual CDR with bypass function
- ✧ Specifications compliant with SFF 8472
- ✧ Power Supply :+3.3V
- ✧ Power dissipation <2W
- ✧ Operating case temperature Range:  
Commercial: 0°C to +70°C  
Industrial: -40°C to +85°C
- ✧ RoHS compliant

**Features:**

- ✧ UP to 25.78Gb/s data links
- ✧ Hot-Pluggable SFP28 footprint
- ✧ Duplex LC connector
- ✧ LWDM COOL DFB Laser and PIN receiver
- ✧ Metal enclosure, for lower EMI
- ✧ Up to 10km on 9/125m SMF
- ✧ 2-wire interface with integrated Digital Diagnostic monitoring

**Applications:**

- ✧ 25GE LR
- ✧ Data center
- ✧ 25G Ethernet
- ✧ CPRI

**Part Number Ordering Information**

OP3010D-LXX	SFP28 LR 10km LWDM optical transceiver with full real-time digital diagnostic monitoring , 0~70°C , 25GE
OP3010DI-LXX	SFP28 LR 10km LWDM optical transceiver with full real-time digital diagnostic monitoring , -45°C ~+85°C , 25GE

**Description:**

OPWAY's OP3010D-LXX SFP28 transceivers are designed for use in Ethernet links up to 25.78Gb/s data rate and up to 10 km link length. They are compliant SFF-8472 , and compatible with SFF-8432 and applicable portions of SFF-8431. The product is RoHS compliant and lead-free per Directive 2011/96/EU.

The transceiver consists of four sections: the LD driver, the limiting amplifier, the LWDM DFB laser and the PIN photo-detector. The module data link up to 10KM in 9/125um single mode fiber.

The optical output can be disabled by a TTL logic high-level input of Tx Disable. Tx Fault is provided to indicate that degradation of the laser. Loss of signal (LOS) output is provided to indicate the loss of an input optical signal of receiver or the link status with partner.

## PRODUCT SELECTION

OP3010D-LXX, XX is the channel number for LWDM wavelength.

Channel	Central Wavelength	Channel	Central Wavelength
L01	1269.23nm	L07	1295.56nm
L02	1273.54nm	L08	1300.05nm
L03	1277.89nm	L09	1304.58nm
L04	1282.26nm	L10	1309.14nm
L05	1286.66nm	L11	1313.73nm
L06	1291.10nm	L12	1318.35nm

## Absolute Maximum Ratings

Parameter	Symbol	Min.	Typ.	Max.	Unit	Note
Case Operating Temperature	Tcase	0		70	°C	Commercial
		-40		85	°C	Industrial
Storage Temperature	T <sub>s</sub>	-40	-	85	°C	
Relative Humidity	RH	0	-	85	%	
Power Supply Voltage	VCC	3.14	3.3	3.47	V	
Supply current	ICC	-		550	mA	Commercial
		-		600	mA	Industrial
Data Rate	BR		25.78		Gbps	TX/RX Rate
Transmission Distance	TD		10		km	

## Electrical Interface Characteristics

Parameter	Symbol	Min.	Typ.	Max.	Unit	Note
<b>Transmitter</b>						
Input differential impedance	R <sub>in</sub>		100		Ω	1
Single ended data input swing	V <sub>in,pp</sub>	180		700	mV	
Transmitter Fault Output-High	V <sub>FaultH</sub>	2	-	V <sub>cc</sub> +0.3	V	
Transmitter Fault Output-Low	V <sub>FaultL</sub>	0	-	0.8	V	
Transmitter Disable Voltage- High	V <sub>DisH</sub>	2	-	V <sub>cc</sub> +0.3	V	
Transmitter Disable Voltage- low	V <sub>DisL</sub>	0	-	0.8	V	
<b>Receiver</b>						
Differential data output swing	V <sub>out,pp</sub>	300		850	mV	2
LOS Output Voltage-High	V <sub>LOSH</sub>	2	-	V <sub>cc</sub> +0.3	V	
LOS Output Voltage-Low	V <sub>LOSL</sub>	0	-	0.8	V	

Notes:

- (1)、Connected directly to TX data input pins. AC coupled thereafter.
- (2)、Into 100 ohms differential termination.

## Optical Characteristics

Parameter	Symbol	Min.	Typ.	Max.	Unit	Note
<b>Transmitter</b>						
Optical Modulation Amplitude (AVG)	PO	+2.0		+7.0	dBm	
Optical Modulation Amplitude (OMA)	OMA	+1.0		+7.0	dBm	
Center Wavelength Range	$\lambda_C$	$\lambda-2.5$	-	$\lambda+2.5$	nm	Refer to product selection
Spectrum Bandwidth(-20dB)	$\Delta\lambda$	-	-	1	nm	
Side-Mode Suppression Ratio	SMSR	30	-	-	dB	
Extinction Ratio	ER	3.5		-	dB	Note (1)
Relative Intensity Noise	RIN 20OMA			-130	dB/Hz	
Average Launched Power(Laser Off)	P <sub>off</sub>	-	-	-30		
Optical return loss tolerance				20	dB	
Transmitter reflectance				-26	dB	
Transmitter eye mask definition {X1, X2, X3, Y1, Y2, Y3} Hit ratio 5x10 <sup>-5</sup> hits per sample		{0.31, 0.4, 0.45, 0.34, 0.38, 0.4}				Note (2)
<b>Receiver-PIN</b>						
Parameter	Symbol	Min.	Typ.	Max.	Unit	Note
Input Optical Wavelength	$\lambda_{IN}$	1250	-	1620	nm	
Damage threshold		3.5			dBm	
Receiver sensitivity (OMA)(EOL), each lane at 5 x 10 <sup>-5</sup> BER	P <sub>sen1</sub>	-	-	-14	dBm	Note (3)
Input Saturation Power (Overload)	PSAT1	2.0	-	-	dBm	Note (3)
Los Of Signal Assert	PA	-30	-	-	dBm	
Los Of Signal De-assert	PD	-	-	-15	dBm	
LOS -Hysteresis	PHys	0.5		6	dB	

Note:

- (1): Measured with a PRBS 231-1 test pattern, @25.78Gb/s.  
 (2): Transmitter eye mask definition, Compliant with IEEE 802.3cc.  
 (3): Measured with Light source 1310nm, ER=3.5dB; BER =<5X10<sup>-5</sup> @PRBS=2<sup>31</sup>-1 NRZ.

## Pin Function Definitions

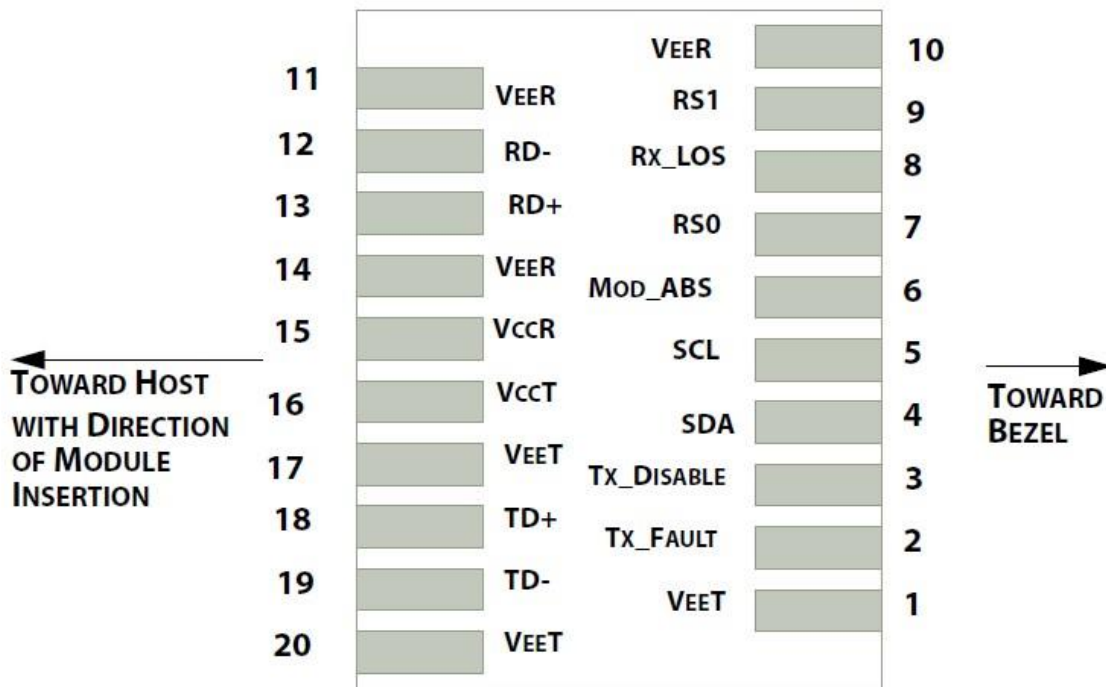

Diagram of Host Board Connector Block Pin Numbers and Name

PIN #	Name	Function	Notes
1	V <sub>EET</sub>	Transmitter Ground. Common with receiver ground.	1
2	TX <sub>FAULT</sub>	Transmitter Fault	2
3	TX <sub>DIS</sub>	Transmitter Disable. Laser output disabled on high or open.	3
4	SDA	2-wire Serial Interface Data Line	4
5	SCL	2-wire Serial Interface Clock Line	4
6	MOD_ABS	Module Absent. Grounded within the module.	4
7	RS0	Rate Select 0. Internal pull down.	5
8	LOS	Loss of Signal Indication. Logic 0 indicates normal operation.	6
9	RS1	Rate Select 1. Internal pull down.	5
10	V <sub>EER</sub>	Receiver Ground. Common with transmitter Ground.	1
11	V <sub>EER</sub>	Receiver Ground. Common with transmitter Ground.	1
12	RD-	Receiver Inverted DATA out. AC coupled.	
13	RD+	Receiver Non-inverted DATA out. AC coupled.	
14	V <sub>EER</sub>	Receiver Ground. Common with transmitter Ground.	1
15	V <sub>CCR</sub>	Receiver Power Supply	
16	V <sub>CCT</sub>	Transmitter Power Supply	
17	V <sub>EET</sub>	Transmitter Ground. Common with receiver ground.	1
18	TD+	Transmitter Non-Inverted DATA in. AC coupled.	
19	TD-	Transmitter Inverted DATA in. AC coupled.	

20	V <sub>EET</sub>	Transmitter Ground. Common with receiver ground.	1
----	------------------	--	---

**Notes:**

1. Circuit ground is internally isolated from chassis ground.
2. TFAULT is an open collector/drain output, which should be pulled up with a 4.7k – 10k Ohms resistor on the hostboard if intended for use. Pull up voltage should be between 2.0V to Vcc + 0.3V. A high output indicates a transmitter fault caused by either the TX bias current or the TX output power exceeding the preset alarm thresholds. A low output indicates normal operation. In the low state, the output is pulled to <0.8V.
3. Laser output disabled on TDIS>2.0V or open, enabled on TDIS<0.8V.
4. Should be pulled up with 4.7kΩ- 10kΩ host board to a voltage between 2.0V and 3.6V. MOD\_ABS pulls line low to indicate module is plugged in.
5. Internally pulled down per SFF-8431 Rev 4.1.
6. LOS is open collector output. It should be pulled up with 4.7kΩ – 10kΩ on host board to a voltage between 2.0V and 3.6V. Logic 0 indicates normal operation; logic 1 indicates loss of signal.

**Block Diagram of Transceiver**

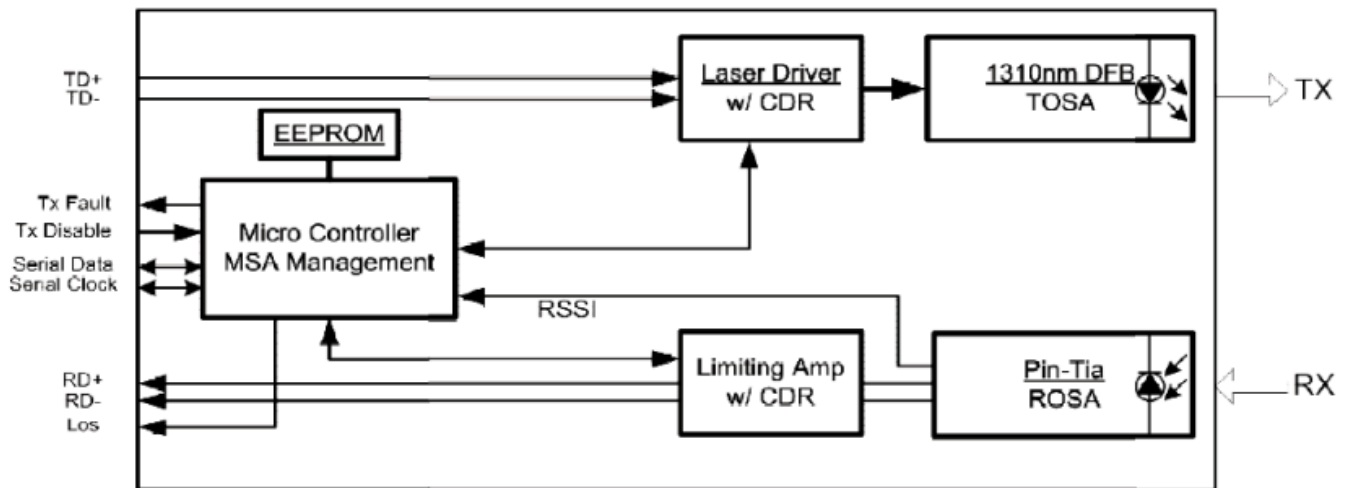

## Outline Dimensions

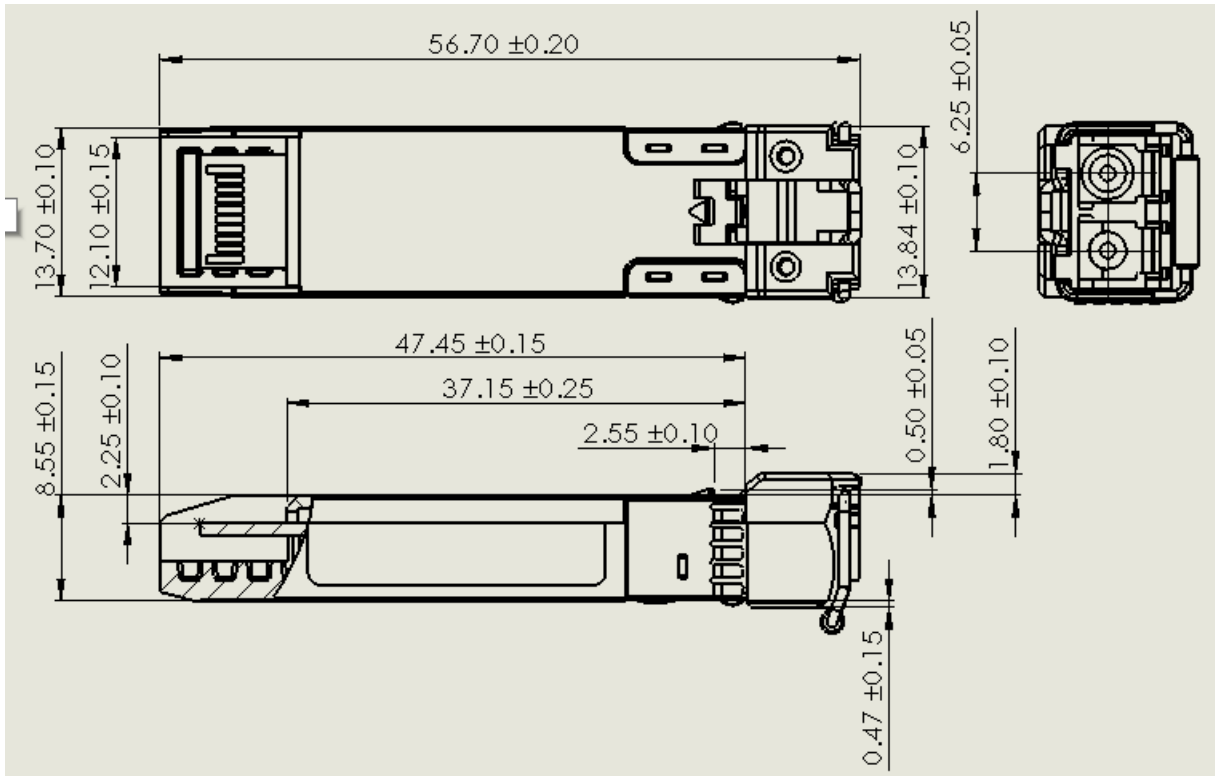

Published by Shenzhen OPWAY Communication Co., Ltd.  
Copyright © OPWAY  
All Rights Reserved