

**FEATURES**

- ✧ Single fiber bi-directional data links TX 9.953Gbps/ Burst Mode RX 2.488Gbps application
- ✧ 0 to 70°C operating case temperature
- ✧ 3.3V, 5V power supply
- ✧ XFP package with SC/UPC Receptacle connector
- ✧ Hot-pluggable capability
- ✧ High power 1577nm EML DFB LD
- ✧ High sensitivity 1270nm APD
- ✧ Support 20km transmission distance with SMF
- ✧ Low EMI and excellent ESD protection
- ✧ Digital diagnostic monitor interface
- ✧ RoHS6 compliance

**APPLICATIONS**

- ✧ XGPON1 OLT (ODN:N1 Class)

**STANDARDS**

- ✧ Complies with INF-8077i
- ✧ Complies with ITU-T G.987.2
- ✧ Complies with FCC 47 CFR Part 15, Class B
- ✧ Complies with FDA 21 CFR 1040.10 and 1040.11 except for deviations pursuant to Laser Notice No. 50, dated June 24, 2007

ABSOLUTE MAXIMUM RATING					
Parameter	Symbol	Min.	Max.	Unit	Notes
Storage Ambient Temperature	T <sub>STG</sub>	-40	85	°C	
Operating Case Temperature	T <sub>C</sub>	0	70	°C	
Operating Humidity	OH	5	90	%	
VCC3 Power Supply Voltage	VCC	0	3.6	V	
VCC5 Power Supply Voltage	VCC	0	5.5	V	

RECOMMENDED OPERATING CONDITION						
Parameter	Symbol	Min.	Typ.	Max.	Unit	N
Operating Case Temperature	T <sub>C</sub>	0		+70	°C	
VCC3 Power Supply Voltage	V <sub>CC</sub>	3.13	3.3	3.47	V	
VCC5 Power Supply Voltage	V <sub>CC</sub>	4.75	5	5.25	V	
VCC3 Power Supply Current	ICC		-	1000	mA	
VCC5 Power Supply Current	ICC		-	500	mA	
Date Rate			9.953/2.488		Gbps	
Date Rate Drift		-100		+100	PPM	

**Shenzhen Opway Communication Co., Ltd.**

TRANSMITTER OPTICAL CHARACTERISTICS						
Parameter	Symbol	Min.	Typ.	Max.	Unit	Notes
Optical Center Wavelength	$\lambda_c$	1575		1580	nm	
Optical Spectrum Width (-20dB)	$\Delta\lambda$	-	-	1	nm	
Side Mode Suppression Ratio	SMSR	30			dB	
Average Launch Optical Power	AOP	+2		+6	dBm	Launched into SMF
Power-OFF Transmitter Optical Power				-39	dBm	Launched into SMF
Extinction Ratio	ER	8.2			dB	PRBS2 <sup>31</sup> -1 @9.953Gbps
Transmitter Reflectance				-10	dB	
Transmitter tolerance to reflected optical power		-15			dB	
Transmitter and Dispersion Penalty	TDP			1	dB	Transmit on 20km SMF
Optical Waveform Diagram	Compliant with ITU-T 987.2					Figure 1,Mask Margin>5%

TRANSMITTER ELECTRICAL CHARACTERISTICS						
Parameter	Symbol	Min.	Typ.	Max.	Unit	Notes
Data Input Differential Swing		120		820	mV	CML input, AC coupled
Input Differential Impedance		90	100	110	$\Omega$	
Transmitter Disable Voltage - Low		0		0.8	V	Transmitter On
Transmitter Disable Voltage - High		2.0		V <sub>CC</sub>	V	Transmitter Off
Transmitter Fault Voltage - Low		0		0.4	V	Transmitter On
Transmitter Fault Voltage - High		2.4		V <sub>CC</sub>	V	Transmitter Fault

**TRANSMITTER EYE MASK DEFINITIONS AND TEST PROCEDURE**

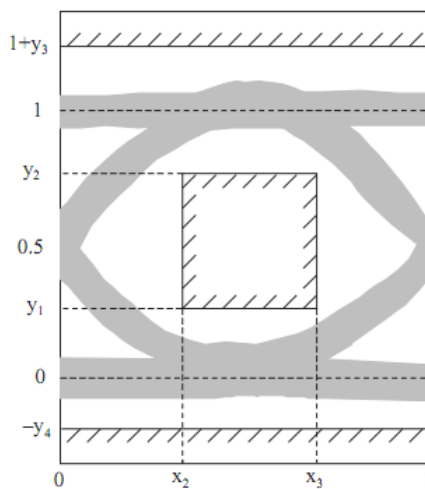

Figure 1 XGPON Transmitter Eye Mask Definitions

X3-X2	Y1	Y2	Y3	Y4	Unit
0.2	0.25	0.75	0.25	0.25	UI

RECEIVER OPTICAL CHARACTERISTICS						
Parameter	Symbol	Min.	Typ.	Max.	Unit	Notes
Operating Wavelength		1260		1280	nm	
Sensitivity	SEN			-27.5	dBm	PRBS 2 <sup>23</sup> -1@2.488Gbps BER ≤1×10 <sup>-4</sup>
Saturation Optical Power	SAT	-7			dBm	PRBS 2 <sup>23</sup> -1@2.488Gbps BER ≤1×10 <sup>-4</sup>
Burst Dynamic Range		15			dB	
Signal Detect Assert Level				-29	dBm	
Signal Detect De-assert Level		-45			dBm	
Loss Of Signal Hysteresis		0.5		6	dB	
Receiver Reflectance				-20	dB	

RECEIVER ELECTRICAL CHARACTERISTICS						
Parameter	Symbol	Min.	Typ.	Max.	Unit.	Notes
Receiver Amplitude Recovery Time	T <sub>rec</sub>			64	bit	Figure 2
Data Output Differential Swing		400		1200	mV	CML output, DC coupled
Reset width	T <sub>rw</sub>	32			bits	
Reset-Low		0		0.8	V	
Reset-High		2.0		V <sub>cc</sub>	V	
Signal Detect Assert Time	T <sub>sda</sub>			100	ns	
Signal Detect De-assert Time	T <sub>sdd</sub>			12.8	ns	Refer to the Reset signal rising edge
Signal Detect Voltage-Low		0		0.4	V	
Signal Detect Voltage-High		2.4		V <sub>cc</sub>	V	
RSSI Trigger-Low		0		0.8	V	
RSSI Trigger-High		2.0		V <sub>cc</sub>	V	
RSSI Trigger Delay	T <sub>D</sub>	0		100	ns	Figure 4
RSSI Trigger Width	T <sub>w</sub>	350			ns	Figure 4
I <sup>2</sup> C Access Prohibited Time	T <sub>P</sub>	500			μs	Figure 4

**TIMING PARAMETER DEFINITIONS IN BURST MODE SEQUENCE**

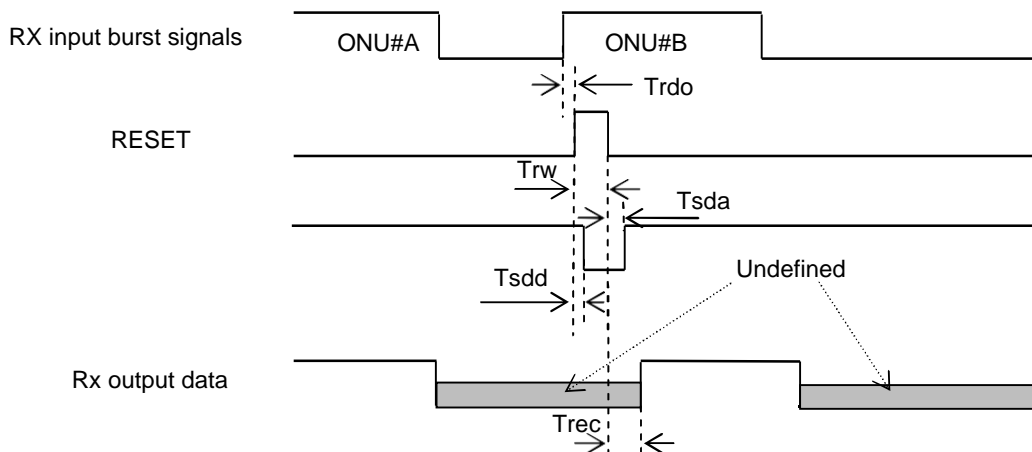

**Figure 2 Timing Parameter Definitions in Burst Mode Sequence**

**BURST MODE RECEIVER DYNAMIC RANGE**

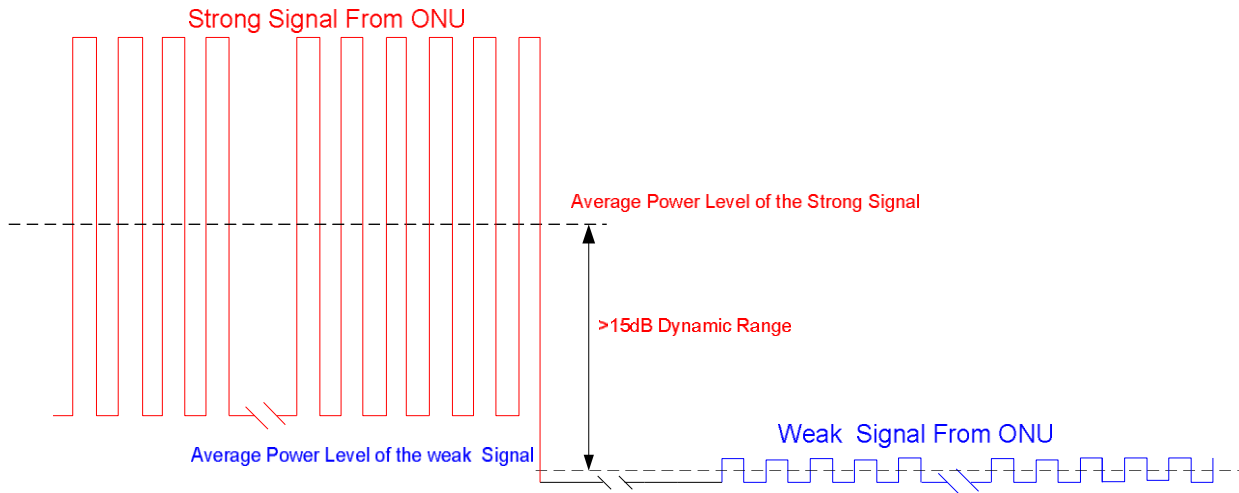

**Figure 3 Burst Mode Receiver Dynamic Range in XGPON System**

**TIMING PARAMETER DEFINITIONS IN RSSI TRIGGER**

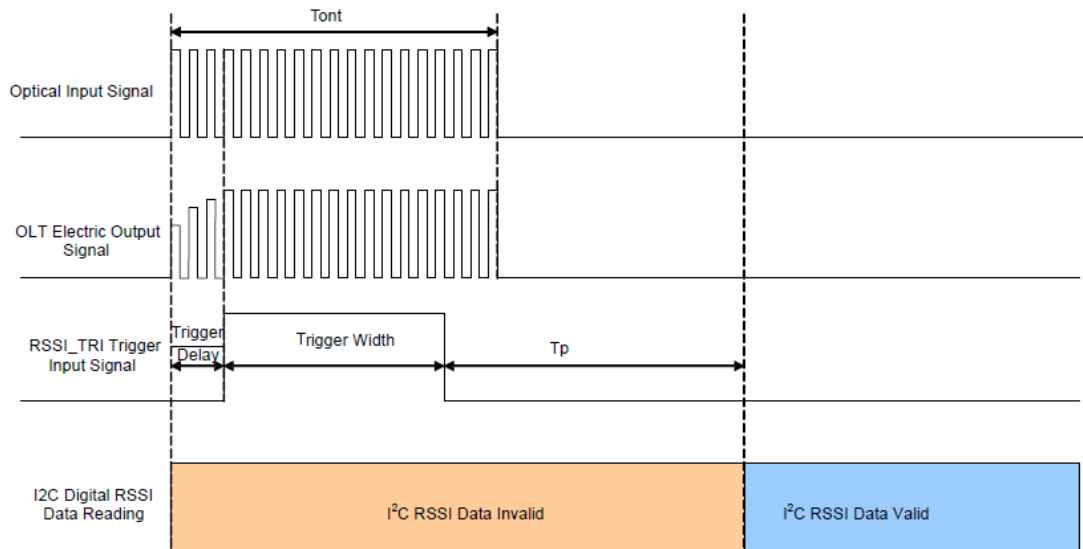

**Figure 4 Timing Parameter Definitions in RSSI Trigger**

PIN DESCRIPTION			
PIN	Name	Description	Notes
1	GND	Module Ground	
2	TX Fault	Transmitter Fault Indication	LVTTTL, High Indicates TX Laser Fault
3	N.C.	Not be Connected in the transceiver	
4	N.C.	Not be Connected in the transceiver	
5	TX_DIS	Transmitter Disable	LVTTTL, Low: transmitter on
6	VCC5	+5V Power Supply	
7	GND	Module Ground	
8	VCC3_TX	Transmitter 3.3V Power Supply	
9	VCC3_RX	Receiver 3.3V Power Supply	
10	SCL	The clock line	The clock line of two wire serial interface
11	SDA	The data line	The data line of two wire serial interface
12	MOD_ABS	Indicates Module is not present.	LVTTTL, this pin shall be pulled-up by Host and grounded in the module.
13	RX_Reset	Burst Receiver Reset	LVTTTL, High level Reset
14	RX_SD	Receiver signal detected indication	LVTTTL, high level indicates burst packet is detected
15	GND	Module Ground	
16	GND	Module Ground	
17	RD-	inverted Received Data Out	CML Output, DC coupled, Squelched by LOS
18	RD+	Non-inverted Received Data Out	CML Output, DC coupled, Squelched by LOS
19	GND	Module Ground	
20	N.C.	Not be Connected in the transceiver	
21	RSSI_TRIG	RSSI trigger for Transceiver A/D converter	LVTTTL, High active
22	NC	Not be Connected in the transceiver	
23	GND	Module Ground	
24	N.C.	Not be Connected in the transceiver	
25	N.C.	Not be Connected in the transceiver	
26	GND	Module Ground	
27	GND	Module Ground	
28	TX-	Inverted Transmit Data in	CML input, AC coupled
29	TX+	Non-Inverted Transmit Data in	CML input, AC coupled
30	GND	Module Ground	

PIN OUT DRAWING

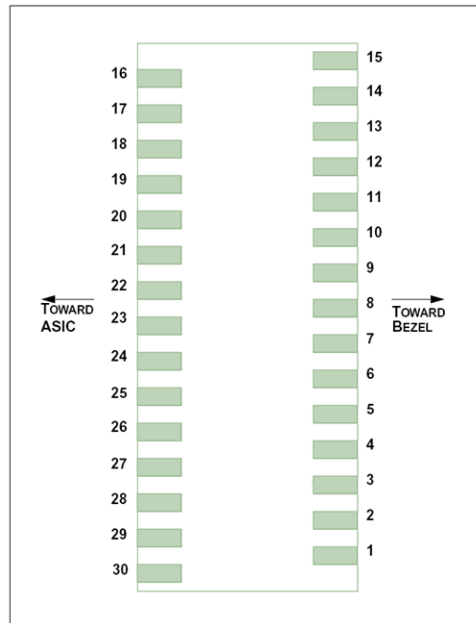

Figure 5 Pin Out Drawing

TYPICAL INTERFACE CIRCUIT

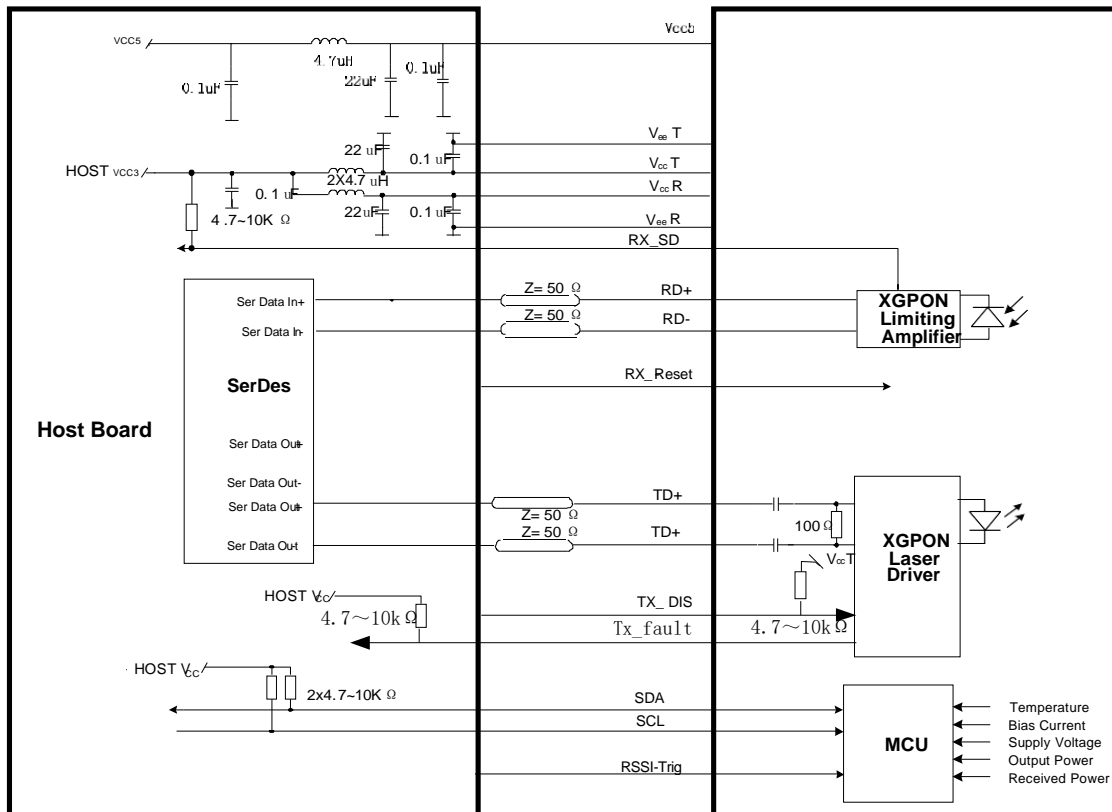
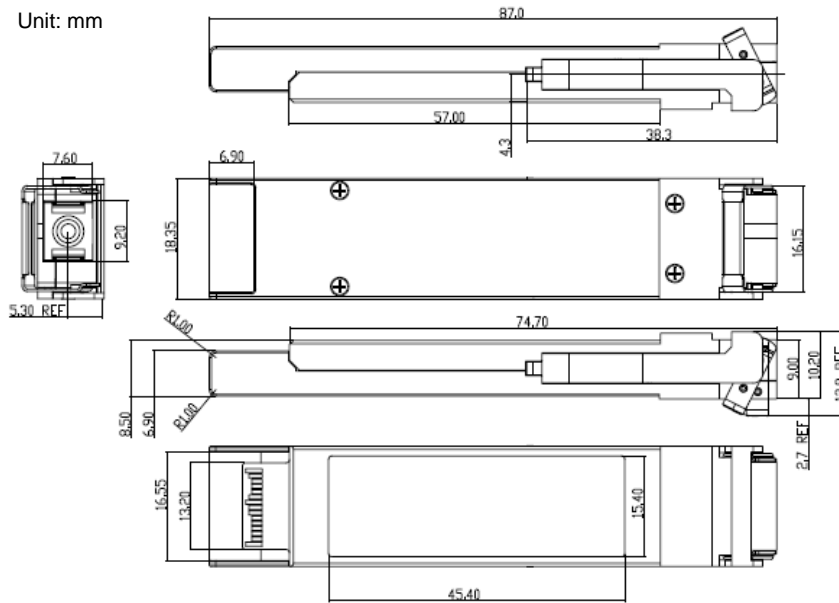

Figure 6 Typical Interface Circuit

**PACKAGE OUTLINE**



**Figure 7 Package Outline**

**EEPROM INFORMATION**

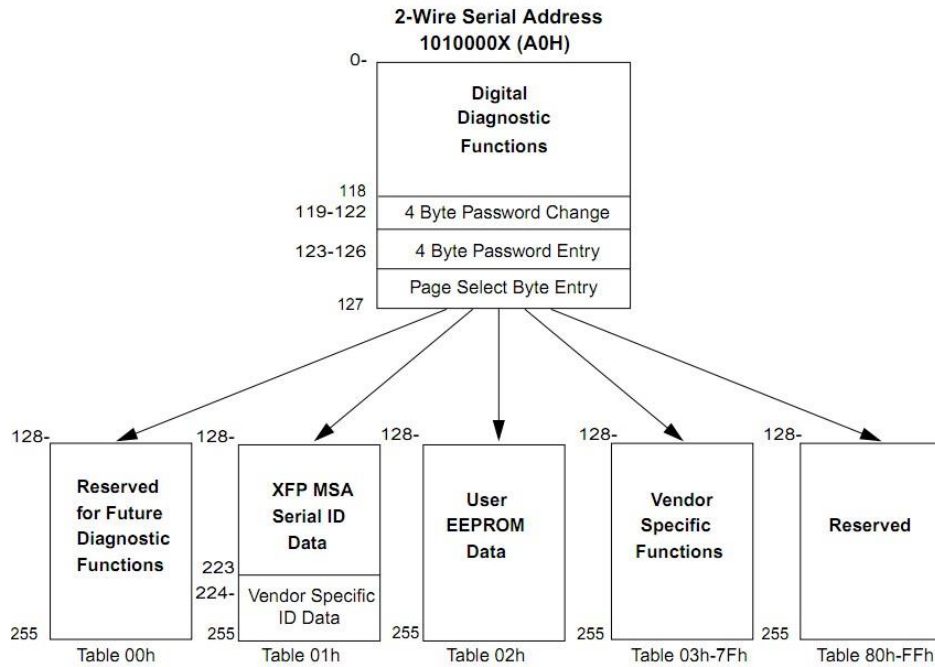

**Figure 8 EEPROM Memory Map Specific Data Field Descriptions**

**DIGITAL DIAGNOSTIC MONITORING INTERFACE**

Parameter	Range	Accuracy	Calibration	Notes
Temperature	-5 to 75°C	±3°C	Internal	1LSB = 1/256°C
Voltage	3.0 to 3.6V	±3%	Internal	1LSB = 0.1mV
Bias Current	0 to 131mA	±10%	Internal	1LSB = 2uA
TX Power	0 to 8dBm	±3dB	Internal	1LSB = 0.1uW
RX Power monitor	-29 to -7dBm	±3dB	Internal	1LSB = 0.1uW

OPWAY reserves the right to make changes to the products or information contained herein without notice. No liability is assumed as a result of their use or application.

No rights under any patent accompany the sale of any such products or information.

Published by Shenzhen OPWAY Communication Co., Ltd.

Copyright © OPWAY

All Rights Reserved