



- ✧ Duplex LC connector
- ✧ RoHS compliant and Lead Free
- ✧ Up to 10 km on 9/125µm SMF
- ✧ Single +3.3V Power Supply
- ✧ Built-in digital diagnostic functions
- ✧ Commercial operating temperature range: 0°C to 70°C

Features:

- ✧ Supports 1.0 to 11.3Gb/s bit rates
- ✧ Hot-Pluggable
- ✧ Uncooled 1310nm DFB laser

Applications:

- ✧ 10GBASE-LR/LW 10G Ethernet
- ✧ 1200-SM-LL-L 10G Fibre Channel
- ✧ SONET OC-192 / SDH STM-64

Description:

Opway’ OP3910D is a very compact 10Gb/s optical transceiver module for serial optical communication applications at 10Gb/s. The OP3910D converts a 10Gb/s serial electrical data stream to 10Gb/s optical output signal and a 10Gb/s optical input signal to 10Gb/s serial electrical data streams. The high speed 10Gb/s electrical interface is fully compliant with SFI specification.

The high performance 1310nm DFB transmitter and high sensitivity PIN receiver provide superior performance for Ethernet applications at up to 10km links.

The SFP+ Module compliant with SFF-8431, SFF-8432 and IEEE 802.3ae 10GBASE-LR. Digital diagnostics functions are available via a 2-wire serial interface, as specified in SFF-8472.

The fully SFP compliant form factor provides hot pluggability, easy optical port upgrades and low EMI emission.

● Absolute Maximum Ratings

Parameter	Symbol	Min.	Typical	Max.	Unit
Power Supply Voltage	V _{CC}	0		3.6	V
Storage Temperature	T _s	-40		85	°C
Operating Case Temperature	T _A	0		70	°C
Relative Humidity	RH	0		85	%
RX Input Average Power	P _{max}	-		0	dBm

● Recommended Operating Environment

Parameter	Symbol	Min.	Typical	Max.	Unit
Power Supply Voltage	V _{CC}	3.135	3.3	3.465	V
Power Supply Current	I _{cc}			300	mA

Power Consumption	P			1.0	W
Operating Case Temperature	T _C	0		70	°C

● **Electrical Characteristics (T_{OP} = 0 to 70 °C, V_{CC} = 3.0 to 3.60 Volts)**

Parameter	Symbol	Min.	Typical	Max.	Unit	Note
Transmitter Section:						
Input differential impedance	R _{in}		100		Ω	1
Single ended data input swing	V _{in PP}	180		700	mVp-p	2
Transmit Disable Voltage	V _D	V _{cc} - 1.3		V _{cc}	V	3
Transmit Enable Voltage	V _{EN}	V _{ee}		V _{ee} + 0.8	V	
Receiver Section:						
Single ended data output swing	V _{out,pp}	300		850	mv	
Data output rise time and fall time	t _r / t _f	30			ps	4
LOS Fault	V _{losfault}	2		V _{CC_host}	V	5
LOS Normal	V _{los norm}	V _{ee}		V _{ee} +0.8	V	5

Notes:

1. Connected directly to TX data input pins. AC coupling from pins into laser driver IC.
2. Per SFF-8431 Rev 3.0
3. Into 100 ohms differential termination.
4. 20 – 80%. Measured with Module Compliance Test Board and OMA test pattern. Use of four 1's and four 0's sequence in the PRBS 9 is an acceptable alternative. SFF-8431 Rev 3.0.
5. LOS is an open collector output. Should be pulled up with 4.7kΩ – 10kΩ on the host board. Normal operation is logic 0; loss of signal is logic 1.

● **Optical Parameters(T_{OP} = 0 to70 °C, V_{CC} = 3.00 to 3.60 Volts)**

Parameter	Symbol	Min.	Typical	Max.	Unit	Note
Transmitter Section:						
Center Wavelength	λ _t	1260	1310	1355	nm	
spectral width	Δλ			1	nm	
Average Optical Power	P _{avg}	-6		-1	dBm	1
Optical Power OMA	P _{oma}	-5.2			dBm	
Laser Off Power	P _{off}			-30	dBm	
Extinction Ratio	ER	3.5			dB	
Transmitter Dispersion Penalty	TDP			3.2	dB	2
Relative Intensity Noise	Rin			-128	dB/Hz	3
Optical Return Loss Tolerance		20			dB	
Receiver Section:						
Center Wavelength	λ _r	1260		1355	nm	
Receiver Sensitivity	Sen			-12.6	dBm	4
Stressed Sensitivity (OMA)	Sen ₂			-10.3	dBm	4

Los Assert	LOS _A	-30		-	dBm	
Los Dessert	LOS _D			-13.5	dBm	
Los Hysteresis	LOS _H	0.5			dB	
Overload	Sat	0			dBm	5
Receiver Reflectance	R _{Rx}			-12	dB	

Notes:

1. Average power figures are informative only, per IEEE802.3ae.
2. TWDP figure requires the host board to be SFF-8431 compliant. TWDP is calculated using the Matlab code provided in clause 68.6.6.2 of IEEE802.3ae.
3. 12dB reflection.
4. Conditions of stressed receiver tests per IEEE802.3ae. CSRS testing requires the host board to be SFF-8431 compliant.
5. Receiver overload specified in OMA and under the worst comprehensive stressed condition.

● **Pin Assignment**

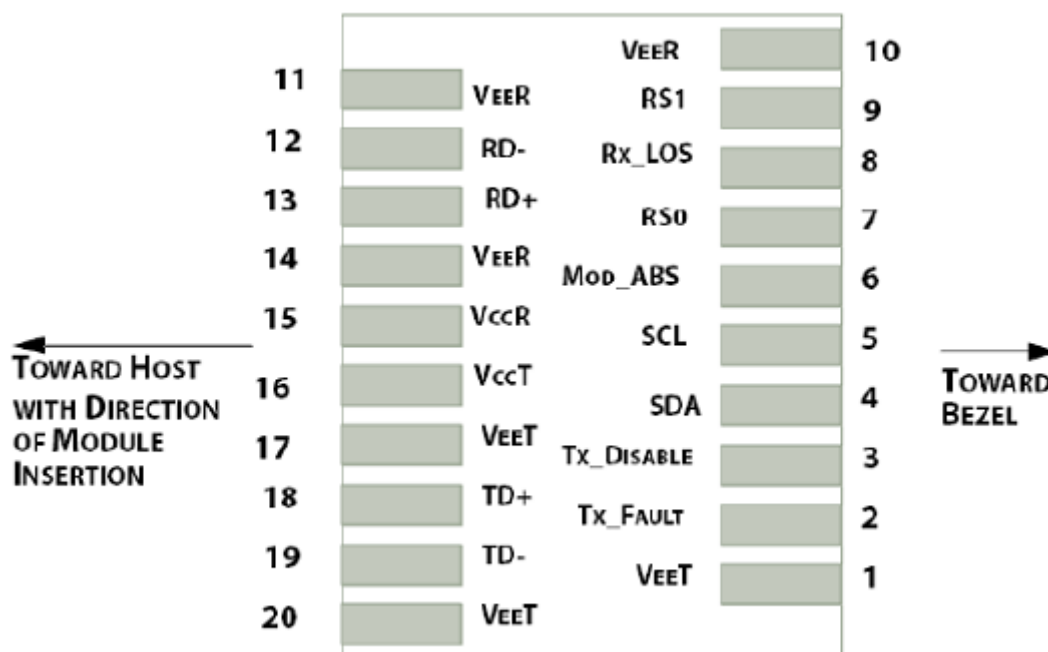

Diagram of Host Board Connector Block Pin Numbers and Names

● **Pin Function Definitions**

PIN #	Name	Function	Notes
1	VeeT	Module transmitter ground	1
2	Tx Fault	Module transmitter fault	2
3	Tx Disable	Transmitter Disable; Turns off transmitter laser output	3
4	SDL	2 wire serial interface data input/output (SDA)	
5	SCL	2 wire serial interface clock input (SCL)	
6	MOD-ABS	Module Absent, connect to VeeR or VeeT in the module	2
7	RS0	Rate Select 0. Not Used	
8	LOS	Receiver Loss of Signal Indication	4
9	RS1	Rate Select 1. Not Used	
10	VeeR	Module receiver ground	1
11	VeeR	Module receiver ground	1
12	RD-	Receiver inverted data out put	
13	RD+	Receiver non-inverted data out put	
14	VeeR	Module receiver ground	1
15	VccR	Module receiver 3.3V supply	
16	VccT	Module transmitter 3.3V supply	
17	VeeT	Module transmitter ground	1
18	TD+	Transmitter inverted data out put	
19	TD-	Transmitter non-inverted data out put	
20	VeeT	Module transmitter ground	1

Note:

- 1.The module ground pins shall be isolated from the module case.
- 2.This pin is an open collector/drain output pin and shall be pulled up with 4.7K-10Kohms to Host_Vcc on the host board.
- 3.This pin shall be pulled up with 4.7K-10Kohms to VccT in the module.
- 4.This pin is an open collector/drain output pin and shall be pulled up with 4.7K-10Kohms to Host_Vcc on the host board.

● **SFP Module EEPROM Information and Management**

The SFP modules implement the 2-wire serial communication protocol as defined in the SFP -8472. The serial ID information of the SFP modules and Digital Diagnostic Monitor parameters can be accessed through the I²C interface at address A0h and A2h.

The memory is mapped in Table 1.

Detailed ID information (A0h) is listed in Table 2.

And the DDM specification at address A2h.

For more details of the memory map and byte definitions, please refer to the SFF-8472, “Digital Diagnostic Monitoring Interface for Optical Transceivers”. The DDM parameters have been internally calibrated.

Table 1. Digital Diagnostic Memory Map (Specific Data Field Descriptions)

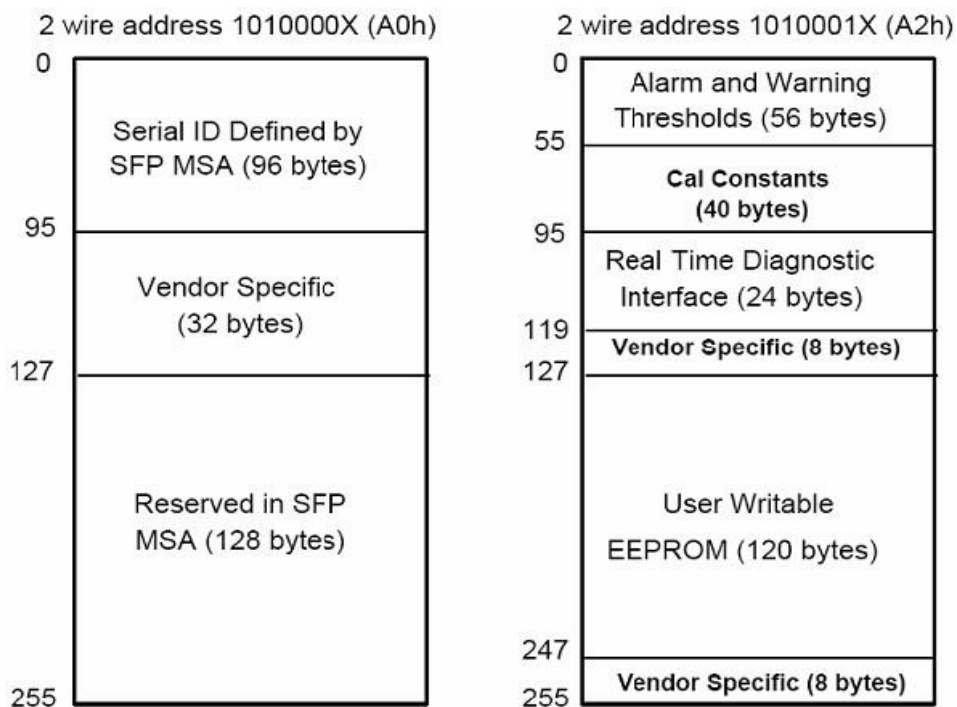

Table 2 - EEPROM Serial ID Memory Contents (A0h)

Data Address	Length (Byte)	Name of Length	Description and Contents
Base ID Fields			
0	1	Identifier	Type of Serial transceiver (03h=SFP)
1	1	Reserved	Extended identifier of type serial transceiver (04h)
2	1	Connector	Code of optical connector type (07=LC)
3-10	8	Transceiver	10G Base-LR
11	1	Encoding	64B/66B
12	1	BR, Nominal	Nominal baud rate, unit of 100Mbps
13-14	2	Reserved	(0000h)
15	1	Length(9um)	Link length supported for 9/125um fiber, units of 100m
16	1	Length(50um)	Link length supported for 50/125um fiber, units of 10m
17	1	Length(62.5um)	Link length supported for 62.5/125um fiber, units of 10m
18	1	Length(Copper)	Link length supported for copper, units of meters
19	1	Reserved	
20-35	16	Vendor Name	SFP vendor name: OPWAY
36	1	Reserved	
37-39	3	Vendor OUI	SFP transceiver vendor OUI ID
40-55	16	Vendor PN	Part Number: "OP3910D" (ASCII)
56-59	4	Vendor rev	Revision level for part number
60-62	3	Reserved	
63	1	CCID	Least significant byte of sum of data in address 0-62
Extended ID Fields			

64-65	2	Option	Indicates which optical SFP signals are implemented (001Ah = LOS, TX_FAULT, TX_DISABLE all supported)
66	1	BR, max	Upper bit rate margin, units of %
67	1	BR, min	Lower bit rate margin, units of %
68-83	16	Vendor SN	Serial number (ASCII)
84-91	8	Date code	OPWAY's Manufacturing date code
92-94	3	Reserved	
95	1	CCEX	Check code for the extended ID Fields (addresses 64 to 94)
Vendor Specific ID Fields			
96-127	32	Readable	OPWAY specific date, read only
128-255	128	Reserved	Reserved for SFF-8079

● **Digital Diagnostic Monitor Characteristics**

Data Address	Parameter	Accuracy	Unit
96-97	Transceiver Internal Temperature	±3.0	°C
98-99	VCC3 Internal Supply Voltage	±5.0	%
100-101	Laser Bias Current	±10	%
102-103	Tx Output Power	±3.0	dBm
104-105	Rx Input Power	±3.0	dBm

● **Regulatory Compliance**

The OP3910D complies with international Electromagnetic Compatibility (EMC) and international safety requirements and standards (see details in Table following).

Electrostatic Discharge (ESD) to the Electrical Pins	MIL-STD-883E Method 3015.7	Class 1(>1000 V)
Electrostatic Discharge (ESD) to the Duplex LC Receptacle	IEC 61000-4-2 GR-1089-CORE	Compatible with standards
Electromagnetic Interference (EMI)	FCC Part 15 Class B EN55022 Class B (CISPR 22B) VCCI Class B	Compatible with standards
Laser Eye Safety	FDA 21CFR 1040.10 and 1040.11 EN60950, EN (IEC) 60825-1,2	Compatible with Class 1 laser product.

● **Recommended Circuit**

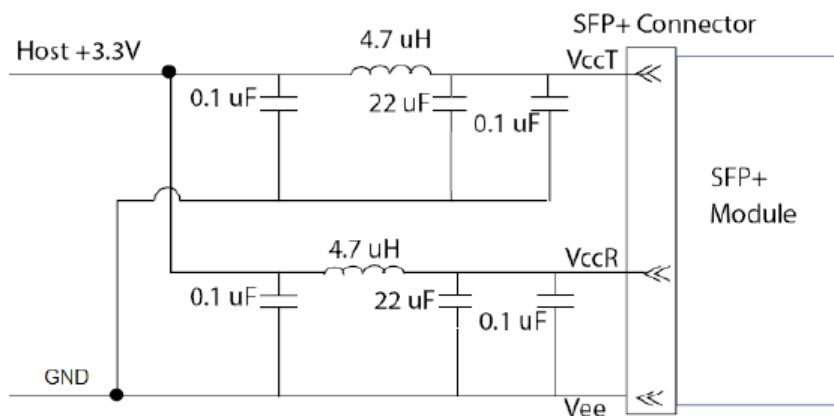

Recommended Host Board Power Supply Circuit

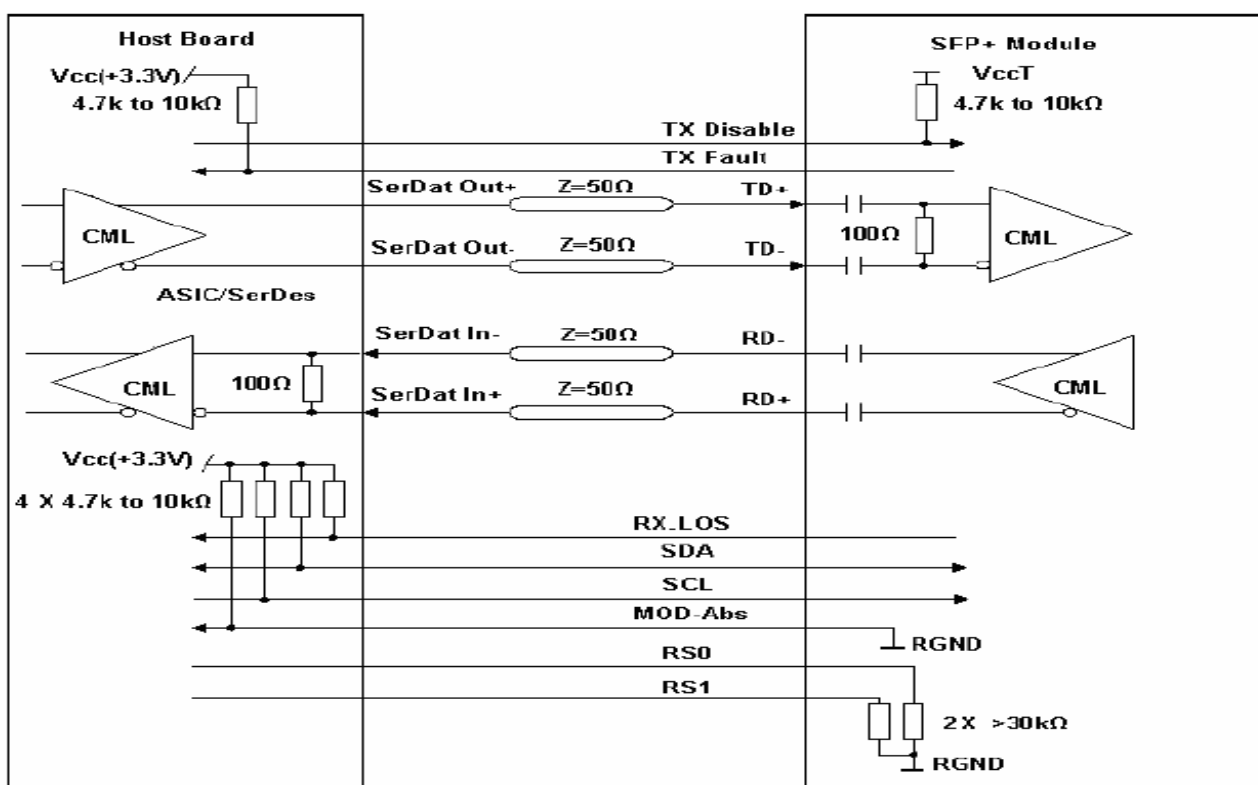

Recommended High-speed Interface Circuit

● **Mechanical Dimensions**

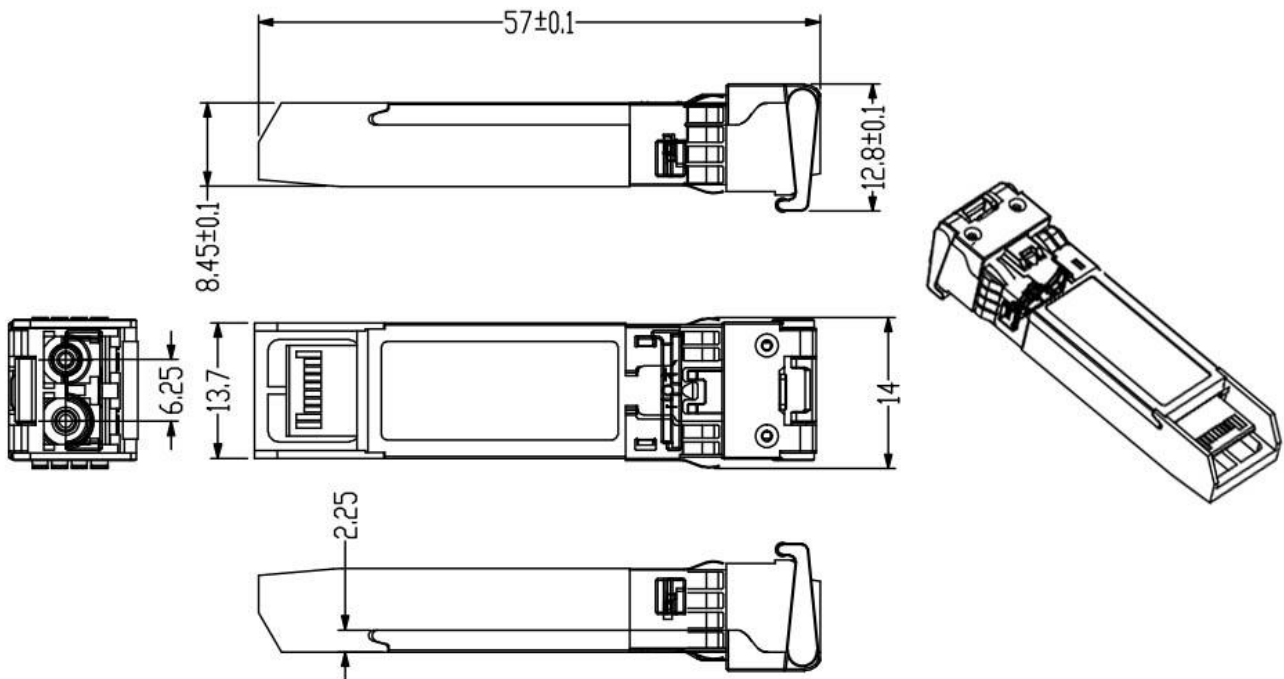

Mechanical Drawing

OPWAY reserves the right to make changes to the products or information contained herein without notice. No liability is assumed as a result of their use or application. No rights under any patent accompany the sale of any such products or information.

Published by Shenzhen OPWAY Communication Co., Ltd.

Copyright © OPWAY

All Rights Reserved